

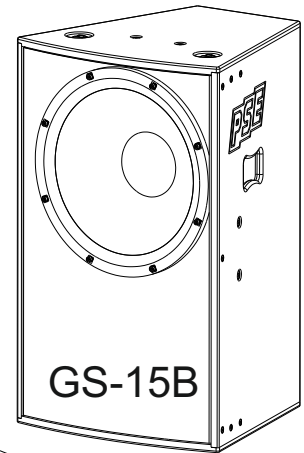

GS-15B

low mid extension for GS-15

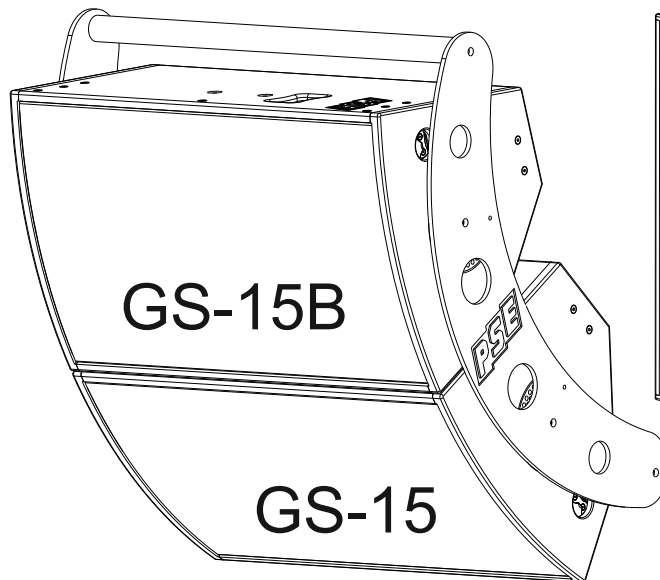
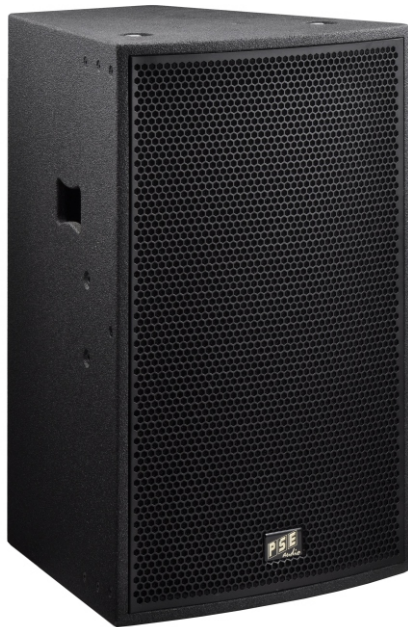

Features GS-15B

- 1x15" speaker ferrite (100mm voice coil)
- 7 air-lock mounting points
- 6 M8 mounting points
- 1 M10 mounting point
- 1 multi gauge plate 360° / 5° steps
- 2 Neutrik speakon 4-pin
- 2 Neutrik speakon 8-pin
- bass link function
- high-mid link function
- perforated steel front grill powder coated
- acoustic foam 4mm behind front grill
- wood housing plywood 15mm, 27mm
- polyurea (PU) high scratch proof coating

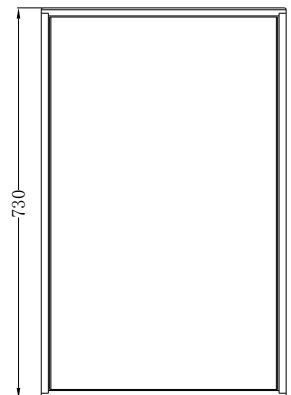
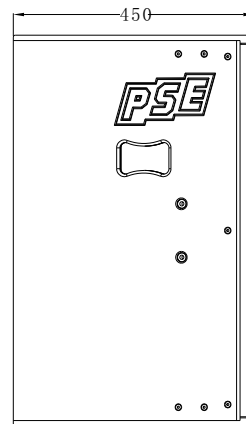
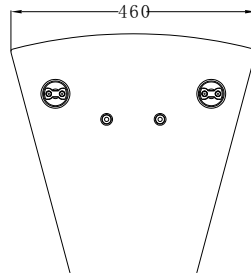

specification	
model	GS-15B
rated impedance	8 Ω
power handling capacity AES/peak*	1000W / 4000W*
available frequency response**	45Hz-1500Hz
max. sound pressure level***	132dB
LF-transducer rated size	15"
LF-transducer voice coil diameter	100mm/4"
LF-transducer magnet structure	Ferrite
dimension h/w/d in mm	730/460/450
weight	39kg

* peak 10ms, with TD-8000 amplifier and GS-15B max controller setup

** -10dB with GS-15B FR controller setup

***1m free field, pink noise, crest factor 10dB, with TD-8000 and GS-15B SPL bi-amp controller setup

small variety of wide range for bass cabinets extension

